



Audio 
precision

APx1701
TRANSDUCER TEST
INTERFACE

Installation Instructions,
Specifications and
User Guide

APx1701 transducer test interface

Installation Instructions, Specifications and User Guide



Copyright © 2011–2018 Audio Precision, Inc.

All rights reserved.

Printed in the United States of America.

No part of this manual may be reproduced or transmitted in any form or by any means, electronic or mechanical, including photocopying, recording, or by any information storage and retrieval system, without permission in writing from the publisher.

Audio Precision, AP, and APx are trademarks of Audio Precision, Inc. Windows™ is a trademark of Microsoft Corporation. Dolby and the double-D symbol are trademarks of Dolby Laboratories, Inc. DTS is a trademark of DTS, Inc.



Audio Precision
5750 SW Arctic Drive
Beaverton, Oregon 97005
503-627-0832
800-231-7350
ap.com

Documentation and Support

This booklet contains safety information, installation instructions, full specifications and a user's guide for the Audio Precision APx1701 transducer test interface. The APx1701 is an accessory to Audio Precision APx500 series audio analyzers, and cannot be operated without an APx500 series analyzer and the APx500 measurement software.

Installation instructions and specifications for APx500 series analyzers are in other documents, provided with the analyzer. Information about using APx500 measurement software is found in the APx500 embedded Help and in the APx500 User's Manual.

The APx500 User's Manual

Detailed information on the operation of the APx1701 transducer test interface is available from the embedded Help installed with the APx500 measurement software, and in the APx500 User's Manual. The user's manual is available as a PDF on the APx500 Application Disc and on the web at ap.com; a hard-copy version can be ordered from Audio Precision or your local distributor.

Audio Test Discs

These discs and more can be ordered from Audio Precision or your local distributor.

- APx-DVD1 is a playable video DVD with menu-driven linear and coded audio test signals for external source use with DVD players.
- APx-CD1 is a playable audio CD with linear audio test signals for external source use with CD players.

ap.com

Visit the Audio Precision web site at ap.com for APx support information and APx resources. You can also contact our Technical Support staff at techsupport@ap.com, or by telephoning 503-627-0832 ext. 4, or 800-231-7350 ext. 4 (toll free in the U.S.A.).

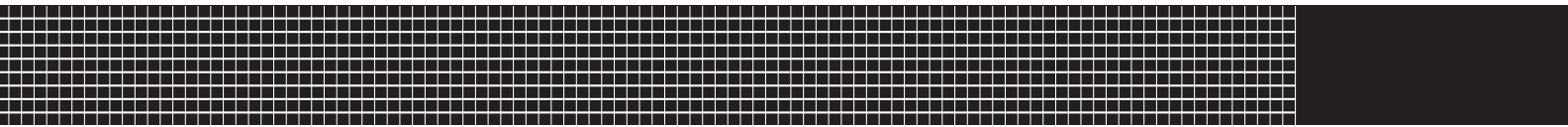

Table of Contents

Safety	i
Sécurité	iii
Seguridad	vii
Installation	1
Installation (FR)	3
Instalación	5
Abbreviations, Terms and Symbols	7
APx1701 specifications	9
User's Guide	13

Safety

Safety Information

Do NOT service or repair this equipment unless properly qualified. Servicing should be performed only by a qualified technician or an authorized Audio Precision distributor.

Do NOT defeat the safety ground connection. This equipment is designed to operate only with an approved three-conductor power cord and safety grounding. Loss of the protective grounding connection can result in electrical shock hazard from the accessible conductive surfaces of this equipment.

Do NOT exceed mains voltage ratings. This equipment is designed to operate only from a 50–60 Hz ac mains power source at 100–240 Vac nominal voltage. The mains supply voltage is not to exceed $\pm 10\%$ of nominal (90–264 Vac).

For continued fire hazard protection, fuses should be replaced **ONLY** with the exact value and type indicated on the rear panel of the instrument and discussed on page 2 of this booklet.

The input measurement terminals are intended to be used for the measurement of audio signals only.

Do NOT substitute parts or make any modifications without the written approval of Audio Precision. Doing so may create safety hazards. Using this product in a manner not specified by Audio Precision can result in a safety hazard.

This product is for indoor use—Installation Category II, Measurement Category I, pollution degree 2.

To clean the enclosure of this product, use a soft cloth or brush to remove accumulated dust. A mild detergent may be used to remove remaining dirt or stains. Do not use strong or abrasive cleaners. Wipe all surfaces with a damp cloth.

This unit is designed for rack mounting, but is also supplied with four feet that can be attached to the bottom surface for desktop use.

Safety Symbols

The following symbols may be marked on the panels or covers of equipment or modules, and are used in this manual:



WARNING!—This symbol alerts you to a potentially hazardous condition, such as the presence of dangerous voltage that could pose a risk of electrical shock. Refer to the accompanying Warning Label or Tag, and exercise extreme caution.



ATTENTION!—This symbol alerts you to important operating considerations or a potential operating condition that could damage equipment. If you see this marked on equipment, refer to the Operator's Manual or User's Manual for precautionary instructions.



FUNCTIONAL EARTH TERMINAL—A terminal marked with this symbol is electrically connected to a reference point of a measuring circuit or output and is intended to be earthed (grounded) for any functional purpose other than safety.



PROTECTIVE EARTH TERMINAL—A terminal marked with this symbol is bonded to conductive parts of the instrument and is intended to be connected to an external protective earthing (grounding) system.



WARNING! HOT SURFACE—This symbol is marked on a surface that may become too hot to touch during operation.

Disclaimer

Audio Precision cautions against using their products in a manner not specified by the manufacturer. To do otherwise may void any warranties, damage equipment, or pose a safety risk to personnel.

Sécurité

Consignes de sécurité

Ne procédez PAS à l'entretien ou à la réparation de cet équipement à moins d'être dûment qualifié(e) pour le faire. L'entretien devrait être effectué uniquement par un technicien qualifié ou un distributeur Audio Precision agréé.

Ne PAS dérouter le branchement de la mise à la terre de sécurité. Cet équipement est conçu pour être utilisé uniquement avec un cordon d'alimentation approuvé avec connecteur à trois conducteurs et mise à la terre de sécurité. La perte de connexion à la mise à la terre protectrice peut entraîner un risque de choc électrique à partir des surfaces conductrices accessibles de cet équipement.

Ne PAS dépasser la tension de réseau nominale. Cet équipement est conçu pour fonctionner uniquement à partir d'une source d'alimentation réseau de 50–60 Hz CA, à une tension nominale de 100–240 V CA. La tension d'alimenta-

tion du réseau ne doit pas dépasser $\pm 10\%$ de la tension nominale (90–264 V CA).

Pour obtenir en permanence la protection contre les risques d'incendie, les fusibles doivent être remplacés UNIQUEMENT par des fusibles de même valeur et type, comme indiqué sur le panneau arrière de l'instrument et précisé à la page 4 de ce livret.

Ces bornes sont destinées à la mesure des signaux audio seulement.

Ne PAS remplacer de pièces ou effectuer de modifications sans l'approbation écrite d'Audio Precision. Si c'est le cas, il pourrait y avoir des risques pour la sécurité. Utiliser ce produit d'une manière non précisée par Audio Precision peut entraîner un risque pour la sécurité.

Ce produit est destiné à une utilisation à l'intérieur—Catégorie d'installation II, Catégorie de mesure I, degré de pollution 2.

Pour nettoyer le boîtier de ce produit, utiliser un chiffon doux ou une brosse douce permettant d'éliminer la saleté accumulée. Un détergent doux peut être utilisé pour éliminer la saleté ou les taches. Ne pas utiliser de produits nettoyants forts ou abrasifs. Essuyer toutes les surfaces à l'aide d'un chiffon humide.

Cette unité est conçue pour être fixée sur bâti, mais elle est aussi équipée de quatre pattes qui peuvent être fixées au-dessous du boîtier pour utilisation sur un bureau.

Symboles de sécurité

Les symboles suivants peuvent être présents sur les panneaux ou les couvercles de l'équipement ou des modules, et sont utilisés dans le présent manuel:



AVERTISSEMENT!—Ce symbole vous informe d'une situation potentiellement dangereuse, par exemple, la présence d'une tension dangereuse qui pourrait présenter un risque de choc électrique. Consultez l'autocollant ou l'étiquette d'avertissement qui l'accompagne, et faites preuve d'une grande prudence.



ATTENTION!—Ce symbole vous informe d'importantes considérations liées au fonctionnement ou d'une condition d'utilisation potentielle qui pourrait endommager l'équipement. Si vous voyez ce symbole sur l'équipement, consultez le manuel de l'opérateur ou le manuel de l'utilisateur pour connaître les instructions préventives.



BORNE DE TERRE FONCTIONNELLE— Les bornes identifiées à l'aide de ce symbole sont reliées électriquement à un point de référence d'un circuit ou d'une sortie de mesure et doivent être raccordées à la terre (mise à la terre) pour toute fonction utilitaire autre que la sécurité.



BORNE DE TERRE DE PROTECTION—Les bornes identifiées à l'aide de ce symbole sont liées à des pièces conductrices de l'instrument et elles doivent être raccordées à un système protecteur de mise à la terre externe.



AVERTISSEMENT! SURFACE CHAUDE—Ce symbole est présent sur toute surface qui peut devenir chaude au toucher pendant le fonctionnement de l'équipement.

Avis de non-responsabilité

Audio Precision déconseille fortement l'utilisation de ses produits d'une manière non spécifiée par le fabricant. Une telle utilisation pourrait annuler toute garantie, endommager l'équipement ou présenter un risque de sécurité pour le personnel.

Seguridad

Información de seguridad

NO proporcione servicio o reparación a este equipo a menos que esté debidamente calificado. El trabajo de servicio deberá ser efectuado solamente por un técnico calificado o un distribuidor autorizado de Audio Precision.

NO modifique la conexión de seguridad a tierra. Este equipo está diseñado para operar solamente con una extensión aprobada de tres conductores puestos a tierra de seguridad. La pérdida de conexión de protección a tierra puede dar como resultado un peligro de descarga eléctrica al tocar las superficies conductoras accesibles de este equipo.

NO exceder las clasificaciones de la tensión de red eléctrica. Este equipo está diseñado para operar solamente de una fuente de suministro eléctrico de 50–60 Hz de corriente alterna a una tensión nominal de 100–240 VCA. La fuente

de suministro de voltaje no debe exceder del $\pm 10\%$ del nominal (90–264 VCA).

Para protección continua contra riesgo de incendio, los fusibles deberán reemplazarse SOLAMENTE con fusibles de valor y tipo exactos indicados en el panel posterior del instrumento y que se explica en la página 6 de este folleto.

Estos terminales están concebidos para usarse solamente para la medición de señales de audio.

NO reemplace partes ni haga modificaciones sin la aprobación por escrito de Audio Precision. Hacerlo podría causar riesgos de seguridad. El uso de este producto en una manera no especificada por Audio Precision puede resultar en un riesgo de seguridad.

Este producto es para uso en interiores-Categoría de instalación II, Categoría de medición I, grado de contaminación 2.

Para limpiar la caja de este producto, utilice un trapo o cepillo suave para remover el polvo acumulado. Se puede utilizar un detergente neutro para remover la suciedad o manchas remanentes. No utilice limpiadores fuertes o abrasivos. Limpie todas las superficies con un trapo húmedo.

Esta unidad está diseñada para montaje sobre un estante, pero también se suministra con cuatro patas que se pueden conectar a la superficie inferior para uso sobre un escritorio.

Símbolos de seguridad

Los siguientes símbolos podrían estar marcados en los paneles o cubiertas del equipo o los módulos, y se utilizan en este manual:



¡ADVERTENCIA!—Este símbolo le alerta sobre una condición potencialmente peligrosa, tal como la presencia de voltaje peligroso que pudiera representar un riesgo de descarga eléctrica. Consulte la etiqueta de advertencia adjunta y tenga mucha precaución.



¡ATENCIÓN!—Este símbolo le alerta de consideraciones operativas importantes o de una condición operativa potencial que pudiera dañar al equipo. Si usted ve este símbolo en

el equipo, consulte el Manual del operador o el Manual del usuario para instrucciones de precaución.



TERMINAL DE TIERRA FUNCIONAL—Un terminal marcado con este símbolo está conectado eléctricamente a un punto de referencia de un circuito de medición o salida y se supone está conectado a tierra (aterrizado) para algún fin funcional diferente a la seguridad.



TERMINAL DE TIERRA DE PROTECCIÓN—Un terminal marcado con este símbolo está enlazado a partes conductoras del instrumento y se supone que está conectado a un sistema externo de protección a tierra (aterrizada).



¡ADVERTENCIA! SUPERFICIE CALIENTE—Este símbolo está marcado sobre una superficie que pudiera calentarse demasiado al tacto durante la operación.

Exención de responsabilidad

Audio Precision advierte contra el uso de este producto de una manera no especificada por el fabricante. El hecho de no hacerlo de la manera indicada invalidaría las garantías,

causaría daño al equipo, o representaría un riesgo de seguridad para el personal.

Installation

Introduction

The APx1701 is an accessory device that must be used in conjunction with both an Audio Precision APx analyzer instrument (sold separately) and a connected personal computer (PC). The APx1701 will not operate without a USB connection to the PC running the APx measurement software, as part of an APx analyzer system.

Installation and safety information for the APx analyzer instrument, the required APx500 measurement software (version 4.3 or later) and PC system requirements can be found in the *Installation and Specifications* booklet provided with the APx analyzer.

Using the APx1701

To use the APx1701, first connect the APx analyzer instrument to the PC and launch the APx500 measurement soft-

ware. Software installation instructions and hardware connection information are provided in the documentation included with the analyzer instrument.

The manual APx500 User's Manual is available as a PDF on the APx500 Application Disc and online at ap.com.

Setting Up the Hardware

Connecting your APx1701 to the electrical mains supply

The APx1701 Transducer Test Interface must be connected to a 50–60 Hz alternating current (ac) electrical mains supply. The minimum voltage is 100 Vac; maximum voltage is 240 Vac. The instrument is fitted with a universal power supply that does not require voltage configuration or change

of fuse type to accept mains voltages within the specified range.

Removing and installing mains fuses

For all rated voltages, use two mains fuses of type 4A T/SB (5x20 mm) 250 V.

To remove the mains fuse carrier module, refer to the figures below and proceed as follows:

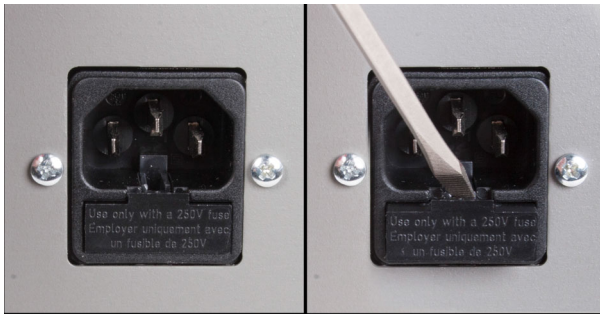

Power entry module

Fuse carrier removal

Remove the mains power supply cord from the connector on the power entry module, located on the APx1701 rear panel. The mains fuse carrier module is part of the power entry module, below the power cord connector.

Insert a small screwdriver into the power cord connector area, reaching into the slot on the mains fuse carrier module. Pry the module out slightly, until you can grasp the module firmly with your fingers. Pull the fuse carrier module out of the power entry module. The two mains fuses are loosely mounted within the fuse carrier module; take care not to let them fall.

Replace the fuses if necessary, using fuses as described above. Carefully reinsert the fuse carrier module into the power entry module, and press it firmly into place.

Connect the power cord from a mains power outlet to the power cord connector on the APx1701 rear panel.

USB connection

The APx500 measurement software communicates with the APx1701 using a USB 2.0 interconnection. Once the software is successfully installed, connect the APx1701 PC INTERFACE to an available USB connector on the measurement PC. Connect the mains power cord to the APx1701 and to a source of ac mains power. Turn the APx1701 front panel power switch ON.

For more information about making measurements with the APx1701, refer to the User's Guide beginning on page 13 of this document, and the *APx500 User's Manual*.

Installation (FR)

Introduction

L'APx1701 est un dispositif accessoire qui doit être utilisé de concert avec l'analyseur APx d'Audio Precision (vendu séparément) et un ordinateur personnel branché à Internet. L'APx1701 ne pourra fonctionner sans une connexion USB à l'ordinateur personnel exécutant le logiciel de mesure APx, comme partie d'un système d'analyse APx.

Les informations relatives à l'installation et les consignes de sécurité relatives à l'analyseur APx, le logiciel de mesure APx500 requis (version 4.3 ou supérieure) et les exigences système de l'ordinateur personnel se trouvent dans le livret d'installation et des caractéristiques techniques livré avec l'analyseur APx.

Utilisation de l'APx1701

Pour utiliser l'APx1701, commencez par brancher l'analyseur APx à l'ordinateur personnel et par lancer le logiciel de

mesure APx500. Les instructions relatives à l'installation du logiciel et celles relatives au branchement des appareils se trouvent dans les documents fournis avec l'analyseur.

Le manuel de l'utilisateur de l'APx500 est offert en format PDF, sur le disque de l'application de l'APx500 et en ligne à l'adresse ap.com.

Configurer l'appareil

Branchement de votre instrument à l'alimentation secteur

L'interface de test du transducteur APx1701 doit être branchée à une alimentation de courant alternatif (c.a.) de 50–60 Hz. La tension minimale est de 100 V c.a.; la tension maximale est de 240 V c.a.

L'instrument est équipé d'une alimentation universelle qui n'exige pas de configuration de tension ni de changement de type de fusible pour accepter les tensions de secteur à l'intérieur de la plage spécifiée.

Retirer et installer des fusibles secteur

Pour toutes les tensions nominales, utilisez deux fusibles secteurs de type 4A T/SB (5 x 20 mm) 250 V.

Pour retirer le module porte-fusibles secteurs, consultez les figures ci-dessous et procédez comme suit :

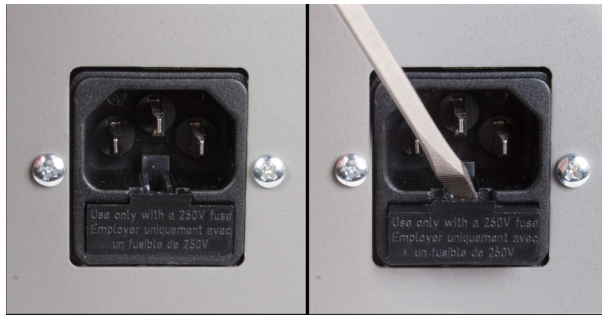

Module d'entrée d'alimentation Retrait du porte-fusibles

Retirez le cordon d'alimentation secteur du connecteur au niveau du module d'entrée d'alimentation qui est situé sur le panneau arrière de l'instrument. Le module porte-fusibles secteurs fait partie du module d'entrée d'alimentation, situé à la droite du connecteur de cordon d'alimentation.

Insérez un petit tournevis dans la zone du connecteur de cordon d'alimentation, dans la fente située sur le module porte-fusibles secteurs. Écartez légèrement le module jusqu'à ce que vous puissiez le saisir fermement entre vos doigts. Tirez le module porte-fusibles du module d'entrée

d'alimentation. Les deux fusibles secteurs sont montés de manière libre dans le module porte-fusibles; prenez soin de ne pas les laisser tomber.

Remplacez les fusibles, au besoin, à l'aide de fusibles identiques à ceux décrits plus bas. Réinsérez délicatement le module porte-fusibles dans le module d'entrée d'alimentation, et insérez-le fermement en position.

Branchez le cordon d'alimentation d'une prise secteur au connecteur de cordon d'alimentation, sur le panneau arrière de l'instrument.

Instalación

Introducción

El APx1701 es un dispositivo que debe utilizarse en forma conjunta tanto con el instrumento analizador Audio Precision APx (vendido por separado) y una computadora personal (PC) conectada. El APx1701 no funcionará sin una conexión USB a una PC con el software de medición APX, como parte de un sistema analizador APx.

La información de instalación y seguridad para el instrumento analizador APx, el software de medición APx500 requerido (versión 4.3 o posterior) y los requisitos del sistema de la PC se pueden encontrar en el folleto “Instalación y Especificaciones” que se proporcionan con el analizador APx.

Uso del APx1701

Para usar el APx1701, conecte primero el instrumento analizador APx a la PC e inicie el software de medición APx500. Las instrucciones de instalación del software y la información para la conexión del hardware se proporcionan en la documentación incluida con el instrumento analizador.

El Manual del usuario del APx500 está disponible como PDF en el Disco de Aplicación del APx500 y en línea en ap.com.

Configuración del hardware

Conexión de su instrumento a la red de energía eléctrica

La interfaz de prueba del transductor del APx1701 debe conectarse a una red de corriente alterna (CA) a 50–60 Hz.

El voltaje mínimo es de 100 VCA, el voltaje máximo es de 240 VCA.

El instrumento está equipado con una fuente de alimentación universal que no requiere configurar el voltaje ni cambiar el tipo de fusible para aceptar voltajes de alimentación dentro del rango especificado.

Extracción e instalación de fusibles de fuente de alimentación

Para todos los voltajes nominales, use dos fusibles de fuente de alimentación tipo 4A T/SB (5x20 mm) 250 V.

Para extraer los fusibles del módulo portador de fusibles de fuente de alimentación, consulte las figuras a continuación y proceda de la siguiente manera:

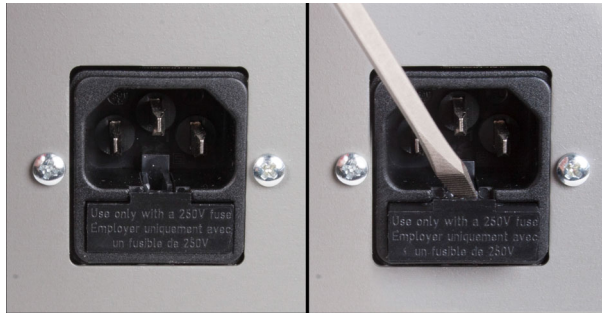

Módulo de entrada de energía **Extracción de portador de fusibles**

Extraiga el cable de la fuente de alimentación del conector en el módulo de entrada de energía, que se localiza en el panel posterior del instrumento. El módulo del portador de fusible de fuente de alimentación es parte del módulo de entrada de energía, a la derecha del conector del cable de alimentación.

Inserte un desarmador pequeño dentro del área del conector de cable de alimentación, alcanzando dentro de la ranura del módulo de portador de fusible de la fuente de alimentación. Separe el módulo levemente, hasta que pueda sujetarlo firmemente con sus dedos. Tire del módulo de portador de fusibles hacia fuera del módulo de entrada de energía. Los dos fusibles de fuente de alimentación están montados holgadamente dentro del módulo de portador de fusible, tenga cuidado de que no se caigan.

Reemplace los fusibles si es necesario, usando los fusibles como se describe a continuación. Reinserte cuidadosamente el módulo portador de fusibles dentro del módulo de entrada de energía, y presione firmemente en su lugar.

Conecte el cable de alimentación desde una salida de fuente de alimentación hacia el conector de cable de alimentación en el panel posterior del instrumento.

Abbreviations, Terms and Symbols

used in the following specifications

ADC or A/D	Analog to Digital converter or conversion.
BW	Bandwidth or Measurement Bandwidth, nominally at -3 dB; a single number indicates only the upper limit.
DAC or D/A	Digital to Analog converter or conversion.
DSP	Digital Signal Processing or Digital Signal Processor.
DUT	Device Under Test, the device to which the generator or analyzer is connected.
EMC	Electro-Magnetic Compatibility, usually refers to both emissions (radiated and conducted via AC mains) and susceptibility.
ENBW	Equivalent Noise Bandwidth, the frequency of an ideal filter having the same rms response to white noise.
FFT	Fast Fourier Transform, a mathematical process converting a signal in the time domain to the frequency domain.
IMD	Inter-Modulation Distortion, a measure of non-linearity using a test signal with two or more components.
RMS or rms	Root Mean Square, an equivalent-power expression of signal amplitude.
SR	Sample Rate, usually as it applies to the conversion rate of A/D and D/A converters or digital audio formats.
THD	Total Harmonic Distortion, rms summation of d2 to d9 (may be bandwidth limited), usually derived from an FFT.
THD+N	Rms measurement of ALL harmonics, spurious signals, and noise within a specified bandwidth.
Typical or Typ	A characteristic that is not guaranteed, usually due to a practical limitation in testing or metrology.
UI	Unit Interval, a measure of time as it applies to digital audio formats. 1 UI=1/(128 • SR)
[]	Indicates a specification in an equivalent unit, for example: 0.030 dB [0.35%] or 10.61 Vrms [30.00 Vpp].
≈	Indicates an approximate or nominal value, or range of values; not guaranteed.

Specifications

APx1701 transducer test interface

with APx500 v4.3 or higher measurement software
January 2018 NP0020.00025 r003

Characteristic	Specifications	Supplemental Information
POWER AMPLIFIER		
Configuration	2 independent channels	<i>Intended for driving electro-acoustic transducers up to 110 kHz maximum. Do NOT use with higher frequencies.</i>
Input Impedance		$\approx 3.32 \text{ k}\Omega \parallel 575 \text{ pF}$, unbalanced
Output Impedance		$\approx 0.13 \Omega$ (0.10 Ω current sense resistor in series with the –Output Terminal)
Voltage Gain, 1 kHz	+20.000 dB [x10.00], non-inverting; R_{SOURCE} must be $50 \Omega \pm 2\%$	<i>Defined as the ratio of the +Output voltage (unloaded) to the <u>open circuit</u> source voltage</i>
Voltage Gain Accuracy, 1 kHz		
	+15°C to +30°C	$\pm 0.005 \text{ dB}$ [$\pm 0.06\%$]
	0°C to +40°C	$\pm 0.009 \text{ dB}$ [$\pm 0.10\%$]
Input Sensitivity, 1 kHz		
	For 100 watts into 8Ω	$\approx 2.874 \text{ Vrms}$ [4.065 Vpk]
	For 60 watts into 4Ω	$\approx 1.600 \text{ Vrms}$ [2.262 Vpk]
	For clipping (unloaded)	$< 4.5 \text{ Vpk}$ (9 Vpp)

Characteristic	Specifications	Supplemental Information
----------------	----------------	--------------------------

Maximum Output Ratings		
$R_{LOAD} \geq 16 \Omega$, both channels	30.0 Vrms	Typically >30.5 Vrms
$R_{LOAD} = 8 \Omega$, one channel only	100 W, 10 Hz to 50 kHz; 95 W, 50 kHz to 100 kHz	Typically >107 W at 1 kHz
$R_{LOAD} = 4 \Omega$, one channel only	60 W, 10 Hz to 50 kHz; 55 W, 50 kHz to 100 kHz	Typically >64 W at 1 kHz
Frequency Response¹		
10 Hz to 20 kHz	± 0.08 dB (DC coupled)	
20 kHz to 50 kHz	± 0.30 dB	
50 kHz to 100 kHz	± 0.80 dB	
Residual Noise²		
A-Weighted	$\leq 6.0 \mu\text{Vrms}$ [-102.2 dBu]	SNR ≈ 134 dB (ref 30 Vrms output)
22 kHz BW	$\leq 7.5 \mu\text{Vrms}$ [-100.3 dBu]	
80 kHz BW	$\leq 13 \mu\text{Vrms}$ [-95.5 dBu]	
500 kHz BW	$\leq 30 \mu\text{Vrms}$ [-88.2 dBu]	
Residual THD+N^{1,2,3}		
10 Hz to 20 kHz	$\leq (-100 \text{ dB} + 13 \mu\text{Vrms})$	80 kHz measurement bandwidth
20 kHz to 100 kHz	$\leq (-80 \text{ dB} + 30 \mu\text{Vrms})$	500 kHz measurement bandwidth
Slew Rate		
		Typically >40 V/ μs
Output DC Offset		
	± 5 mV with input terminated	
Output Crosstalk		
		Typically <-70 dB with $R_{LOAD}=4 \Omega$
MICROPHONE INPUTS		
Number and Types of Inputs		
Balanced	2 each, female XLR	Switchable +48 V phantom power
Unbalanced	2 each, grounded bnc	Switchable 4 mA (+24 V CCP) with TEDS reading capability
Maximum Rated Input		
Balanced	10 Vpk (20 Vpp), differentially	
Unbalanced	5 Vpk (10 Vpp)	

Characteristic	Specifications	Supplemental Information
----------------	----------------	--------------------------

Input Impedance⁴		
Balanced, each side to ground		$\approx 20\text{ k}\Omega \parallel 240\text{ pF} - 300\text{ pF}$
Unbalanced		$\approx 20\text{ k}\Omega \parallel 240\text{ pF} - 300\text{ pF}$
Input AC Coupling		
		time constant $\approx 0.20\text{ s}$; -3 dB is $\approx 0.8\text{ Hz}$
Switching Configuration		
Microphone Output (Pass Thru) 1		Switchable from among microphone balanced inputs 1 and 2, or microphone unbalanced inputs 1 and 2. Also switchable to read the DC output of either unbalanced microphone input.
Microphone Output (pass Thru) 2		Switchable from among microphone balanced input 2 or microphone unbalanced input 2 only.
Residual Noise		
		Determined by the audio analyzer; the inputs are passively switched.
Input Crosstalk ($R_S \leq 600\Omega$)	$\leq (-80\text{ dB} + 1\text{ }\mu\text{V})$ to 20 kHz	
<u>OUTPUT CURRENT SENSE (MONITOR)</u>		
Sensitivity	0.100 V per Amp, $\pm 0.50\%$	0.10 Ω current sense resistor is in series with the - (minus) Output terminal of each amplifier.
Switching Configuration		
		Power amplifier output 1 or 2. Current sense resistor remains in circuit at all times even when not selected.

Characteristic

Specifications

Supplemental Information

GENERAL/ENVIRONMENTAL		
Power Requirements	100 to 240 Vac \pm 10% (90–264 Vac), 50–60 Hz, with safety ground via approved power cord, 360 VA max.	<i>No range switching or fuse changes required over the full operating range of 90–264 Vac.</i>
Temperature	0°C to +40°C operating, –40°C to +75°C storage.	
Humidity	10% to 80%, non-condensing	
Operating Altitude	2,000 m [6,560 feet]	
Stabilization Time	20 minutes	<i>Allow up to 1 hour per 10°C if unit has been exposed to a significant change in temperature. Allow 24–48 hours to recover if condensation has occurred.</i>
EMC	Complies with Directive 2014/30/EC, IEC 61326-1, Ed. 2.0, EN 61326-1:2013. Radiated and conducted emissions are within Class B limits of CISPR 11.	<i>Emissions and immunity levels are influenced by the quality of interface and signal cables attached to the unit. Compliance was demonstrated using Audio Precision cables.</i>
Safety	Complies with Directive 2014/35/EC, IEC 61010-1:2010 Ed. 3.0, EN 61010-1:2010, CAN/CSA-C22.2 No. 61010-1-12, UL Std. No. 61010-1 (3rd Ed.).	<i>This product is for indoor use—Installation Category II, Measurement Category I, pollution degree 2.</i>
Dimensions (W x H x D)	483 x 88 x 372 mm [19.00 x 3.44 x 14.66 in]	<i>Primarily intended for rack mounting. Adding feet for bench-top use adds \approx0.5 in to overall height.</i>
Weight	5.5 kg [12.1 lbs]	
Notes to Specifications		
1.	R_{LOAD} must be \geq 4 Ω .	
2.	For specified noise and distortion performance, a ground bonding wire \leq 10" [25 cm] must be connected between the source and APx1701 chassis.	
3.	Measured with the APx555 only. Other audio analyzers will display higher readings due to their higher internal residual performance.	
4.	Total effective impedance when selected, including the shunting effects of the analyzer input and interconnection cable.	



User's Guide

Introduction

The APx1701 Transducer Test Interface is an APx accessory device with both input and output functions. The APx1701 is primarily designed to drive loudspeakers and headphones in acoustic testing, to measure loudspeaker impedance curves, and to accommodate and power both measurement microphones and microphones under test.

Output Functions

For output measurement functions, the APx1701 provides an audio power amplifier that stands between a driven transducer (typically a loudspeaker system, driver or headphones) and the APx analyzer analog outputs. Additionally, sense resistors are provided for driver impedance measurements.

Input Functions

For input measurement functions, the APx1701 is connected between transducer outputs (typically microphones) and the APx analyzer analog inputs. The APx1701 can provide CCP or phantom powering to attached microphones. TEDS data can be read and passed from a TEDS microphone to APx500.

APx500 measurement software

Control of the APx1701 requires Audio Precision's APx500 measurement software running on the measurement system PC. See the APx500 User's Manual and the embedded Help within the APx500 software for information about addressing the APx1701 from the software.

Mounting and ventilation

The APx1701 is designed to mount in a standard 19-inch relay rack, and is fitted with integral rack ears. The APx1701 is two rack units (2 U) in height.

For proper ventilation to prevent overheating and failure, we recommend that the APx1701 be mounted with at least 1 U of space above and below, and that there be at least 3 inches of space to the rear of the unit.

Never mount an APx1701 in a tightly enclosed rack.

Safety Features

The APx1701 monitors internal conditions to protect itself and the device under test from damage.

If an amplifier channel trips its current limit and causes the amplifier to voltage clip, an alert will be issued.

If the amplifier draw should exceed the capability of the internal power supplies, the power supplies will momentarily shut down and the amplifier inputs will be disconnected by relays. The input relays can be reset from the APx500 software.

If thermal limits at key locations within the APx1701 are exceeded, the amplifier inputs will be disconnected by relays. The input relays can be reset from the APx500 software.

LED indicators

There are two LED indicators on the APx1701 front panel. The Power LED, to the right, is illuminated when AC mains power is applied and the APx1701 is switched ON.

The USB LED, to the left, indicates a number of APx1701 conditions, detailed in the following table.

<i>USB LED</i>	<i>Condition</i>
• OFF	• Power is Off, USB is not connected.
• ON	• Power is On, USB is connected.
• Slow	• Power is OFF, USB is connected
• Fast	• A clip fault, a power fault, or a temperature fault

PC control and data interconnections

The APx1701 must be connected by USB 2.0 to a personal computer running APx500 measurement software (version 4.3 or later) to operate.

If multiple APx1701 interfaces are detected, only the first one encountered will be activated by the software.

APx audio interconnections

Typically, the APx instrument generator unbalanced audio outputs are connected to the APx1701 amplifier inputs, and the APx1701 microphone outputs (pass thru) are connected to the analyzer balanced inputs. See System Connections on page 16.

If impedance curves are to be measured, the Sense Resistor output is connected to an analyzer balanced input.

Ground connection

For best noise performance, the APx1701 and the APx analyzer should have their ground lugs connected with a low-

resistance cable, such as the ground strap provided with the interface.

DUT connections (amplifier outputs)

Each channel of the two-channel audio power amplifier in the APx1701 has an output source resistance of approximately 0.13Ω , including the 0.10Ω current sense resistor.

When one channel is in use, the amplifier is rated at 100 W into 8Ω , or 60 W into 4Ω . The amplifier can drive lower impedances, but is limited to an output current of about 6 A.

When two channels are in use, the amplifier is rated at 30.0 V rms into loads above 15Ω .

Loudspeaker connections

The APx1701 amplifier outputs appear on the 4 pins of the Neutrik NLT4M SpeakON connector. The diagram here shows the pin arrangement for the mating NL4F or NLT4F cable connector, shown from the rear (cable-connection) point of view. Use large gauge, high-quality speaker cable of short length for best results.

The amplifier output signals appear on a four-connector SpeakON connector, wired conventionally according to the following diagram.

Note that rotating and disconnecting a SpeakON connector while under load can result in arcing, which will damage the surface of the contacts and increase parasitic resistance. Do not disconnect while under load.

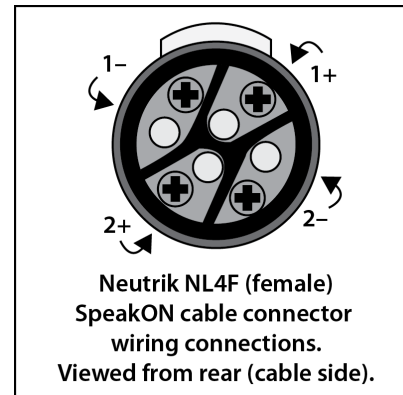

Headphone connections

When connecting to headphones that are fitted with a 1/4-inch or 3.5 mm tip-ring-sleeve (TRS) plug, a SpeakON to TRS jack adapter must be used.

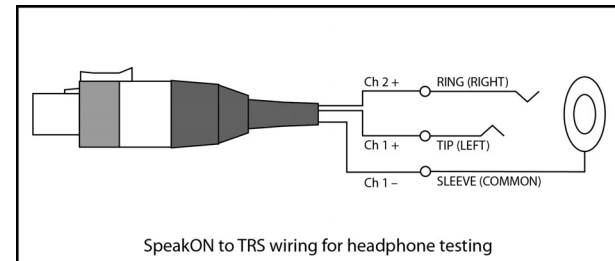

Use only the Ch 1- connection as a return for both channels, as shown. This avoids the unintended paralleling of the sense resistors.

DUT connections (microphone inputs)

The APx1701 is designed to easily interface with common measurement microphones, and with common professional recording and sound reinforcement microphones.

Unbalanced Microphone Inputs

Most measurement microphones have an unbalanced audio output, typically provided on a BNC connector. The BNC Unbalanced Microphone Inputs are designed to connect to such microphones.

Pre-polarized measurement microphones typically use the +24 V CCP (constant current power) system, which can be provided by the APx1701. See Microphone Powering on page 22.

TEDS data can be read from TEDS-enabled microphones connected to an APx1701 unbalanced microphone input. See TEDS data on page 22.

If the microphone requires a proprietary power supply (typical of measurement microphones that require a polarizing voltage) connect the audio output from the power supply to an unbalanced microphone input, using high-quality shielded microphone cable.

Balanced Microphone Inputs

Most professional recording and sound reinforcement microphones have a balanced audio output, typically provided on an XLR connector. The XLR Balanced Microphone Inputs are designed to interface directly with professional recording or sound reinforcement microphones.

Solid-state condenser microphones typically use the +48 V phantom power system, which can be provided by the APx1701. See Microphone Powering on page 22.

Unpowered professional microphones, such as dynamic or ribbon microphones, can be connected to the balanced inputs and operated with the phantom power off.

If the microphone requires a proprietary power supply (typical of tube/valve microphones) connect the audio output from the power supply to a balanced microphone input, using high-quality shielded balanced microphone cable.

Testing with the APx1701

The APx1701 Transducer Test Interface is intended for use with an APx500 Series analyzer and APx500 measurement software. We will look at some typical test cases, beginning on page 17.

System connections

In all cases shown, the APx1701 must be connected to the APx500 analysis system, including the PC running the measurement software and the analyzer instrument hardware.

The connection to the PC is accomplished by a USB 2.0 connection between the PC and the APx1701.

The audio connections between the analyzer and the APx1701 are accomplished using one or two unbalanced shielded BNC-to-BNC cables, and one, two or three balanced shielded XLR-to-XLR cables. Typically, one or two analyzer unbalanced analog outputs are connected to the APx1701 amplifier inputs, and one or two of the APx1701 microphone outputs (pass thru) are connected to the analyzer balanced analog inputs. For impedance tests, the

APx1701 current sense output must also be connected to an analyzer balanced input.

Additionally, a low-resistance ground strap should be connected between the chassis grounds of the APx analyzer and the APx1701.

APx1701/APx analyzer system interconnections

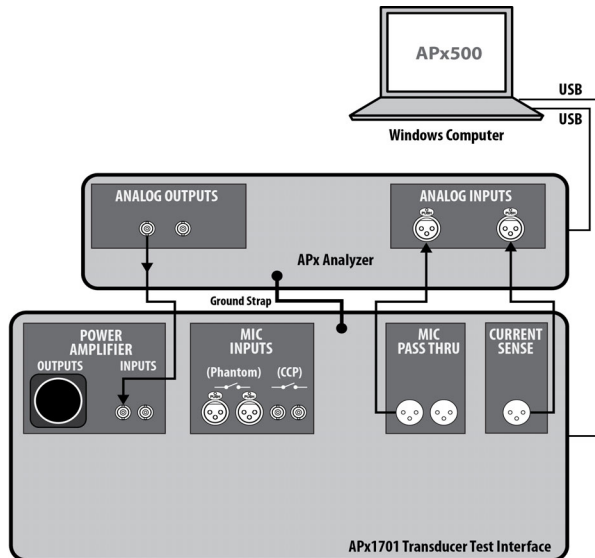

Typical interconnection between the APx1701 and an APx analyzer, using one amplifier channel, one microphone channel and current sense.

Testing a loudspeaker driver

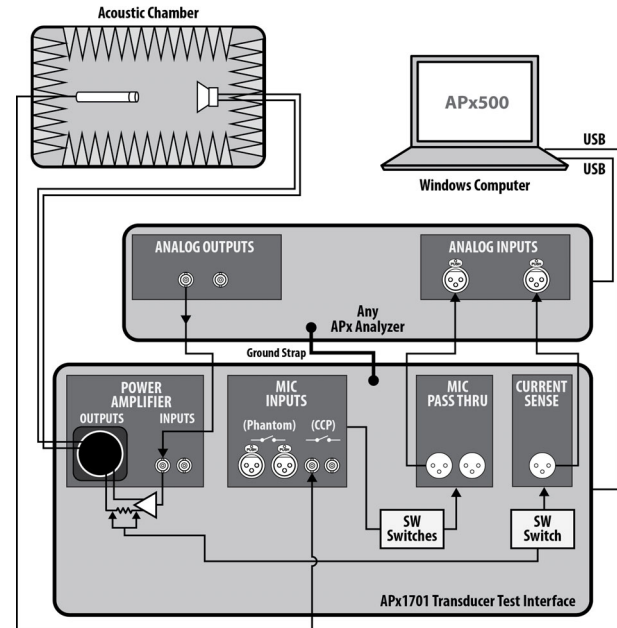

Simplified diagram for acoustic testing and impedance measurement of a loudspeaker driver.

Mount the loudspeaker driver, and connect it to the APx1701 amplifier output channel 1 (pins 1+ and 1- on the SpeakON connector). See Amplifier Output Connection below. Mount the measurement microphone on a micro-

phone stand, and connect it to the APx1701. See Microphone Connections on page 16.

In many cases you may want to place the driver and the microphone in an acoustic chamber with a specified distance between them; for demonstration purposes, you can place them in close proximity in an ordinary, quiet room. In the APx500 software, set the Signal Path I/O to Transducer Interface, and run the Acoustic Response measurement. You will see a number of results, including frequency response, group delay and rub-and-buzz.

Impedance/Thiele-Small measurements are optional, and require the Current Sense connection shown in the diagrams.

Testing two loudspeakers simultaneously

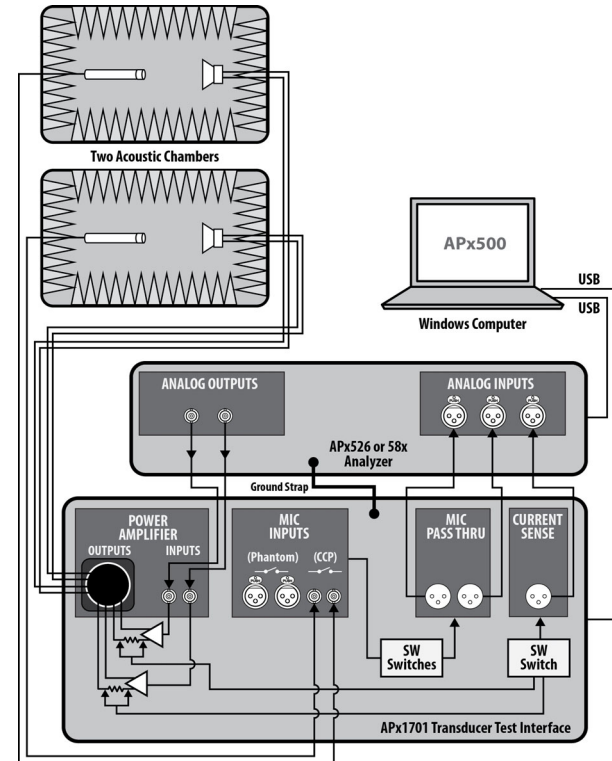

Simplified diagram for acoustic testing and impedance measurement of two loudspeaker drivers.

Testing a loudspeaker (near field/far field)

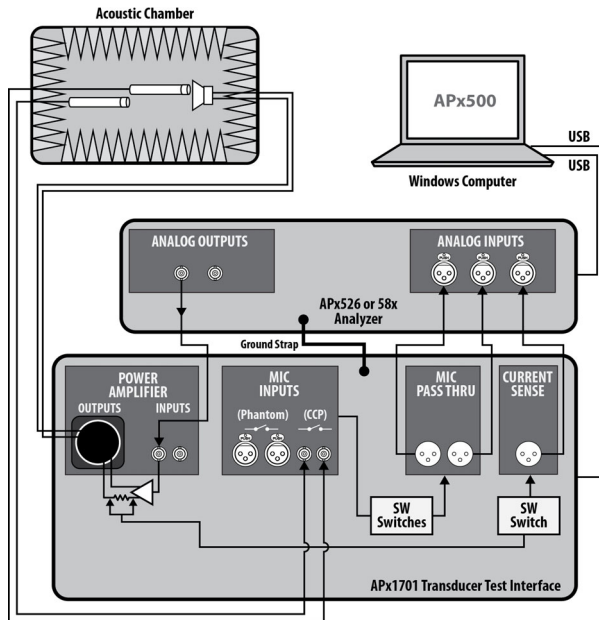

Simplified diagram for acoustic testing and impedance measurement of a loudspeaker driver using near- and far-field microphones.

Testing headphones

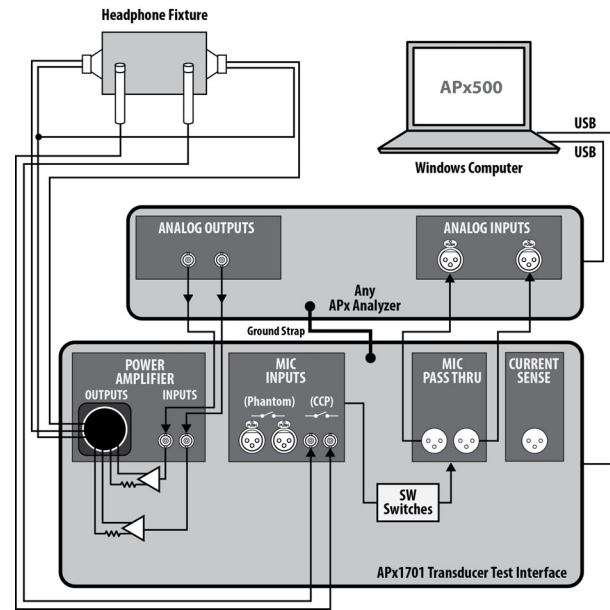

Simplified diagram for acoustic testing of stereo headphones using a headphone fixture.

Mount the headphones to a fixture, and connect the APx1701 amplifier output channels to the headphones. Typically, headphones use a TRS (tip-ring-sleeve) plug, and you should make an adapter cable to accommodate this. See the illustration on page 15. Mount the measurement micro-

phones in the fixture, and connect them to the APx1701. See Microphone Connections on page 16.

In the APx500 software, set the Signal Path I/O to Transducer Interface, and run the Acoustic Response measurement. You will see a number of results, including frequency response, group delay and rub-and-buzz.

Headphones often have impedance curves that do not relate well to Thiele-Small models, and do not provide conventional impedance results. However, in production quality assurance, the impedance test can reveal TRS jack fatigue or failure, often a problem in a busy production environment.

The higher impedance of headphones can result in noisy impedance curves. You can smooth such curves using the Smooth Derived Result in APx500.

Comparing two microphones

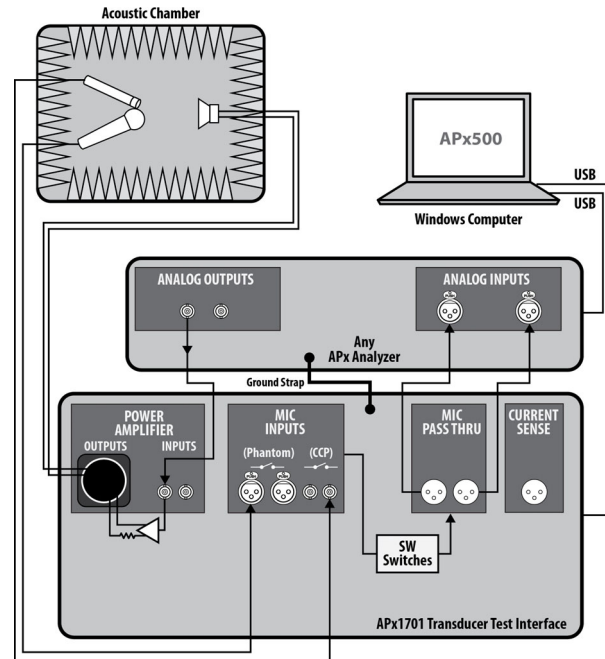

Simplified diagram for testing a professional microphone in comparison to a measurement microphone.

Conveniently mount a full-range loudspeaker, and connect it to the APx1701 amplifier output channel 1 (pins 1+ and 1- on the SpeakON connector). See Amplifier Output Connections on page 15. Mount the microphone to be tested

(DUT) on a microphone stand, and connect it to the APx1701. See Microphone Connections on page 16.

In the APx500 software, set the Signal Path I/O to Transducer Interface, and run the Acoustic Response measurement.

Alternatively, you can mount both the DUT mic and a measurement mic in close proximity, using two input channels and comparing the microphone results.

A further technique to evaluate microphone distortion is to use two loudspeakers, feeding each a different tone, and performing an IMD test on the microphone output, as shown in the following illustration. This will provide a microphone distortion result, with a minimal contribution of distortion from the loudspeaker.

Testing a microphone with split IMD signals

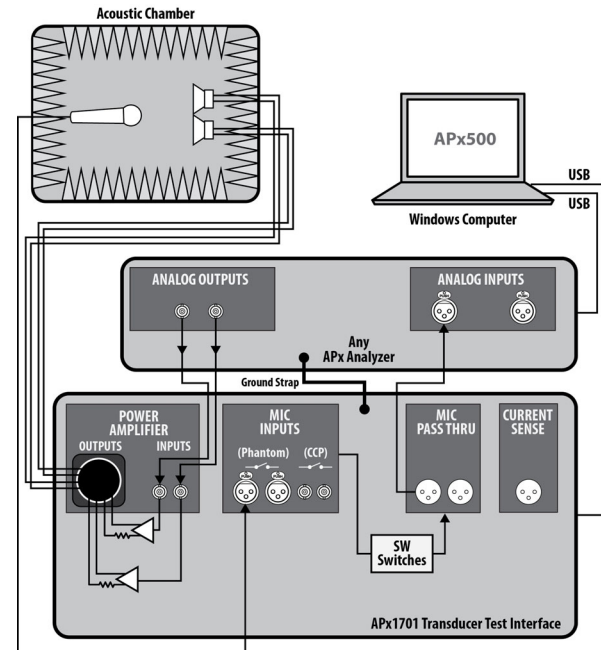

**Simplified diagram
for testing a professional microphone
using the 2-channel IMD method.**

Microphone Powering and the APx1701

Condenser microphones (also called *capacitor microphones*) use a capacitor as the transducer element. All condenser microphones require powering of some sort. Some designs need a polarizing voltage for the transducer element, and all designs need power for the small amplifier and associated circuitry attached to the transducer.

Measurement microphone CCP powering

Measurement microphones that are pre-polarized (using an *electret* condenser for the transducer element) are typically powered by a constant current supply (CCP) power system. The APx1701 can provide +24 Vdc CCP power at 4 mA to such microphones when connected to the unbalanced microphone inputs.

Measurement microphones that require a polarization voltage for the transducer element are typically fitted with a multi-pin connector and are provided with a proprietary power supply from the manufacturer. The APx1701 can use such microphones, but cannot power them. You must provide a power supply.

Studio microphone phantom powering

Condenser microphones designed for recording and sound reinforcement applications are typically balanced devices, and use a powering system called phantom power.

A phantom powered microphone may be pre-polarized, or may develop the polarization voltage internally from the phantom power. The APx1701 can provide +48 Vdc phan-

tom power to such microphones when connected to the balanced microphone inputs.

TEDS data

Some measurement microphones and other transducers store Transducer Electronic Data Sheet (TEDS) information that can be read by connected devices. The Audio Precision APx1701 Transducer Test Interface can read data from TEDS 0.9 and TEDS 1.0 microphones connected to either of the unbalanced microphone inputs. This data is passed to the APx500 software via the USB connection for display, reporting, and entry into calibration dialogs.

For R&D testing, these data are used as data-sheet values in calibration reports. For production testing in controlled production setups and environments, the TEDS data can be used in lieu of actual calibration values.

For best accuracy, it is recommended that microphone sensitivity be measured using an external acoustic source such as a pistonphone.

TEDS is described in detail in the IEEE 1451 family of standards.

APx1701 Self-Test

Audio Precision offers a diagnostic software program called SelfTest.exe, which interrogates the attached hardware and guides the user through a series of procedures to verify the performance of many of the analyzer functions and circuits.

Go to the Audio Precision Web site and download the APx500 Series Self-Test from the Software: Utilities, Projects & Macros section at ap.com.

When used with an APx analyzer, it is possible to run SelfTest.exe to verify the performance of the APx1701. However, since the APx1701 power amplifier must be measured with a load, the SLFT-1701 Self-Test Fixture is required. The SLFT-1701-KIT can be ordered from your sales representative.

The SLFT-1701-KIT provides the required SpeakON, BNC and XLR cables and two 8 Ω load resistors mounted in a small enclosure, the SLFT-1701 Self-Test Fixture.

The SLFT-1701 Self-Test Fixture

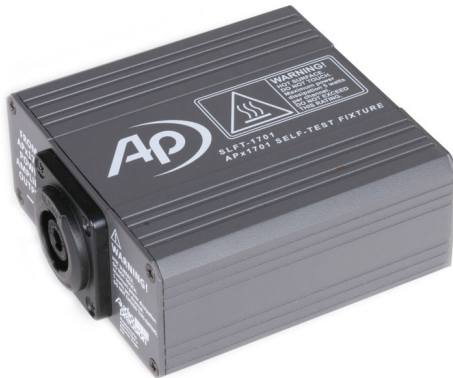

The SLFT-1701 should only be used with an APx-1701 and APx analyzer, using the dedicated Audio Precision self-test program, SelfTest.exe. The SLFT-1701 should only be used with this dedicated test.

WARNING! DO NOT TOUCH



The surface of the SLFT-1701 will get hot during normal use.

MONITOR THIS ACCESSORY WHILE IN USE.

DO NOT EXCEED THIS RATING

Maximum power dissipation is 5 watts per channel.

Use of this accessory beyond maximum power rating will result in hazardous surface temperatures and create a risk of burn injuries or fire.

Do not place on combustible surface while in use.

This accessory should only be used by qualified and trained professionals familiar with power amplifiers, high voltage and the potential for elevated temperatures in this equipment.



Audio Precision, Inc.
5750 SW Arctic Drive
Beaverton, Oregon 97005

800-231-7350

